

# Understanding and Choosing Propellers for Electric Flight

A non-analytical presentation by:

Tom Hunt

Sr. Engineering Specialist

Vehicle Design

Northrop Grumman- Bethpage, NY

PRESENTATION CAN BE FOUND AT: [WWW.SEFLI.ORG/WRAM.HTM](http://WWW.SEFLI.ORG/WRAM.HTM)

Tom Hunt WRAM 2009

# What does a prop do for you?

---

- **When properly chosen, turns your electric powered vehicle from a car (or boat) into an airplane!**
- **When not properly chosen, it either remains a very funny looking car (or boat!) or could possibly make a nice smokin' hole in the middle of that beautiful flying field!**

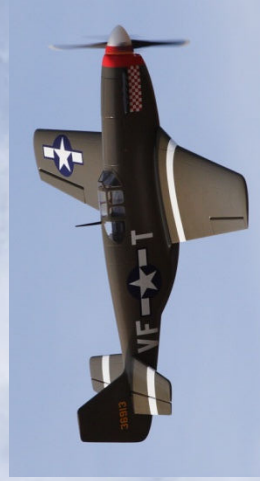

THIS?

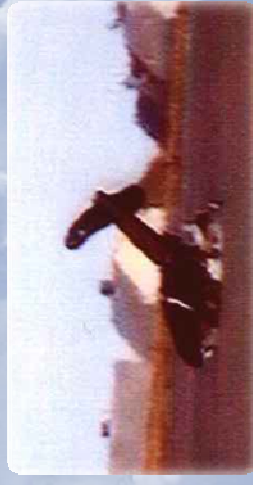

OR THIS?

# How does a prop work for you?

---

**Most props we put on our models respect the laws of physics, primarily:**

**Force (thrust) = mass x acceleration.**

**Simply put: props suck the air ahead of it and spit it out the back faster than when it came in. Considering how little “mass” there is in “air” the acceleration is doing the bulk the work.**

**Though we cannot change the “m” term significantly, we can effect a change in thrust with the “a” term by varying RPM, diameter and pitch. This non-analytical seminar will hopefully enlighten you on how modelers can effect a change in thrust and power required by making proper choices in propellers.**

Tom Hunt WRAM 2009

# Definitions: Geometry of a prop

The physical properties of a prop are diameter, pitch, number of blades, blade area and activity factor (blade shape).

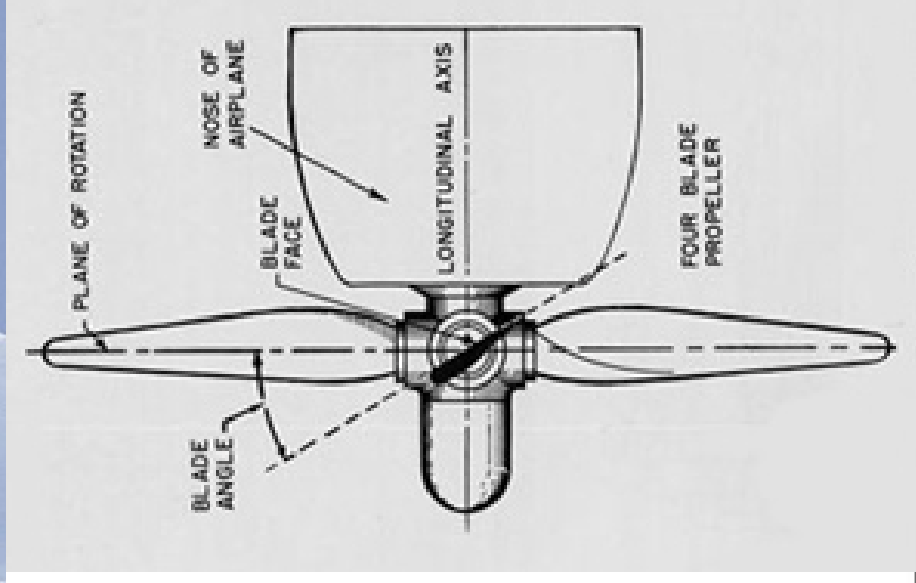
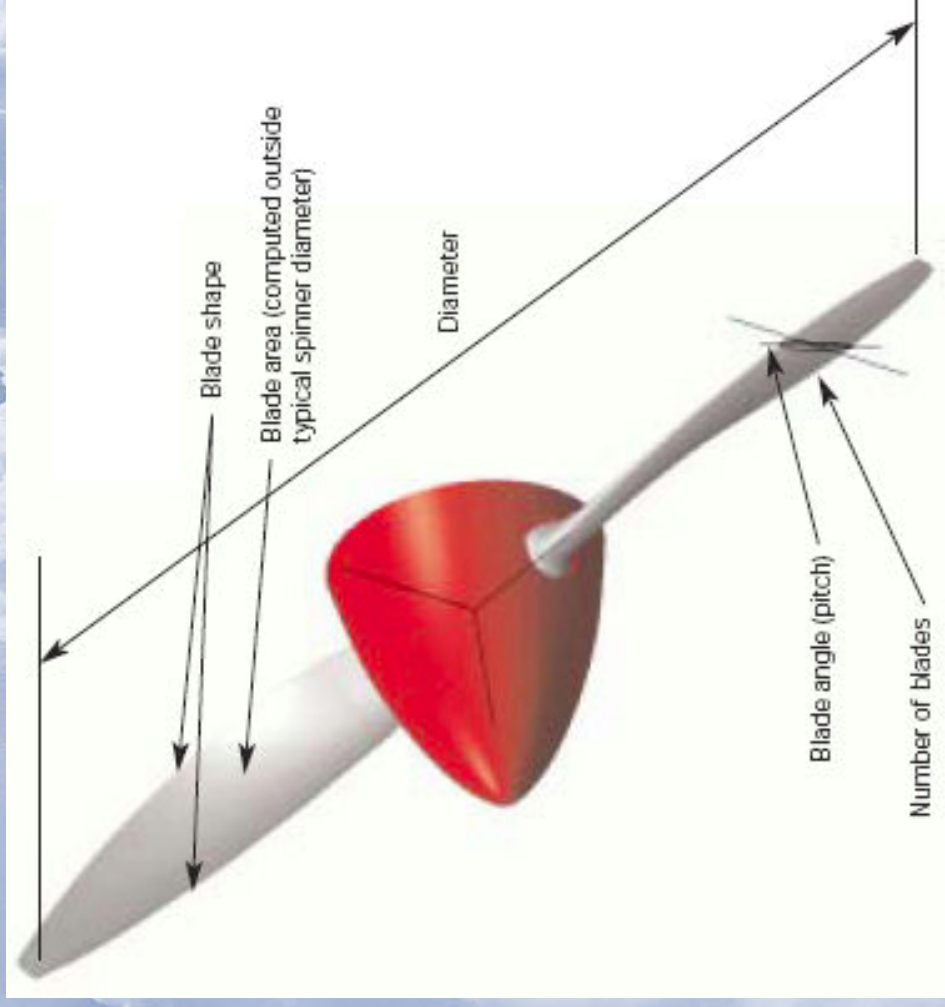

Tom Hunt WRAM 2009

# Definitions: Pitch

Geometric pitch, usually quoted in “inches” is the “bite” the prop takes out of the air. If a 5” pitch propeller were to swing in a solid medium, it would move forward 5” in each revolution. Because air is not “solid”, the propeller “slips”. This true distance the aircraft moves is the “effective” pitch.

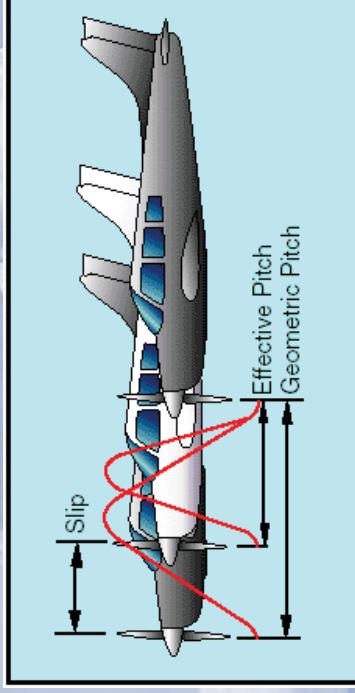

One can think of “slip” as an efficiency, the larger the slip, the worse the efficiency. Since we cannot significantly change the density of air we fly in, “slip” rears it’s ugly head when we put too small a prop on too large a model. The prop wants to go 80mph, but the input power available will only make the model go 40 mph.

Tom Hunt WRAM 2009

# Definitions: Pitch (continued)

Pitch is a measurement of the angle of the blade (chordline) at any spanwise station relative to the plane of the rotation of the propeller. "Helical pitch" props, which comprise 90% of all the model props we buy, have the same pitch throughout the span of the blade. This is NOT often the case with a fixed pitch prop for a "full scale" aircraft. The "pitch" or twist distribution of the propeller is "optimized" for the engine and the flight regime the aircraft most experiences.

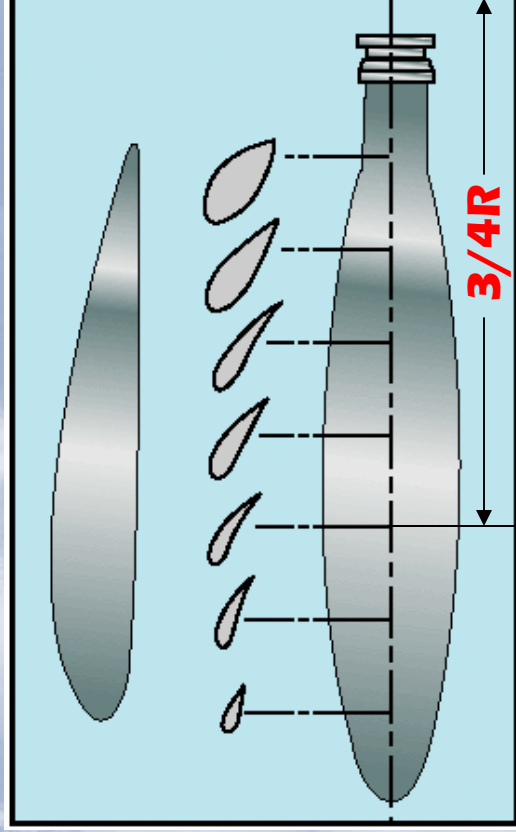

In the case of a variable pitch prop, the "pitch" of the prop is defined as the local pitch of the 3/4R point of the prop.

Tom Hunt WRAM 2009

# Definitions: Activity Factor

**Think of “activity factor” as where most prop blade area is located. If all three propellers below have the same area, the blade with most of the area farther out on the blade, has the highest activity factor.**

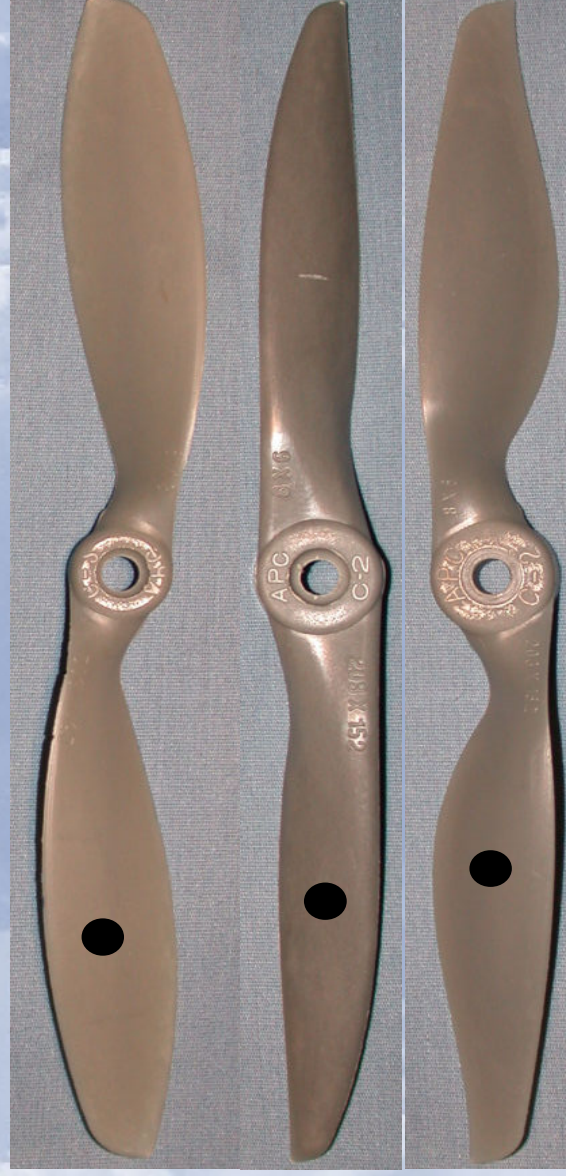

Increasing  
activity  
factor

Tom Hunt WRAM 2009

# Definitions: Activity Factor

**If pitch, diameter and blade area are all the same, then a propeller with a higher “activity factor” will absorb more power at the same RPM as a prop with a lower activity factor**

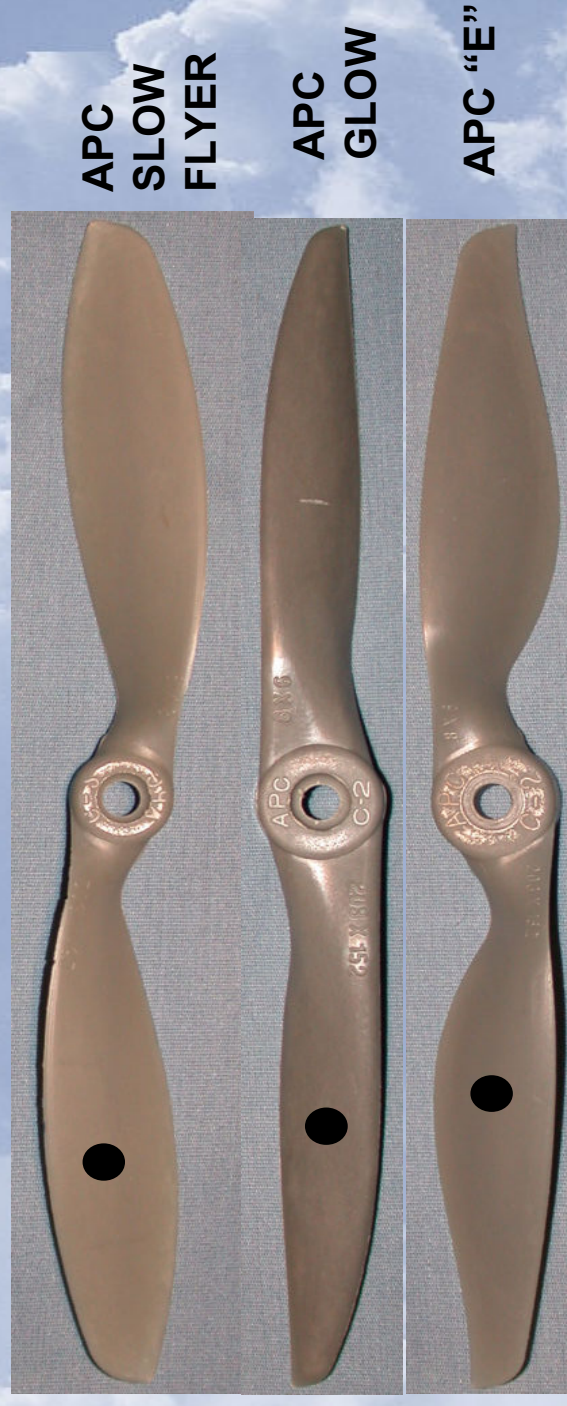

Tom Hunt WRAM 2009



# Definitions: Pitch/Diameter Ratio

---

Since we still live in a “fixed pitch” prop world in the sport of model aviation, the pitch/diameter ratio directs us to either:

**P/D ratios  $<.5$  = Excellent acceleration, excellent climb, but low top speed**

**P/D ratios between  $.5$  and  $.8$  = Good acceleration, good climb, good speed**

**P/D ratios between  $.8$  and  $1.2$  = Poor acceleration, poor climb, excellent speed**

# Thrust from a prop (and the power required)

Thrust can be generated an infinite number of ways:

- Spin a small prop very fast.
- Spin a medium sized prop, medium fast.
- Spin a large prop slowly.

**A simplified equation for computing “static” thrust of a prop:**

Static Thrust (in lbs) =

$0.000000000283 * \text{rpm}^2 * \text{Prop Diameter}^4 * \text{Air Density}/29.92$

**Note that “pitch” does not enter the equation!**

**Also note that the thrust is a “4<sup>th</sup> power” of the diameter.**

**The means that a small increase in diameter will produce a bunch more thrust (assuming you have the power to drive it!)**

**PS.... The equation for POWER absorbed by a prop is a “5<sup>th</sup> power” of the diameter! (raise the prop diameter 10% and the power required to turn the new prop at the same RPM is 60% more!)**

Tom Hunt WRAM 2009

# Static Thrust Vs Dynamic thrust

---

- Data obtained from static thrust measurements (the only kind of thrust easily obtained by a modeler) are NOT reliable to choose between one prop or another.
- Some props are partially or totally stalled in “static conditions”. These are generally props with P/D ratios in excess of .75 (i.e. a 12 x 8).
  - Static thrust Will NOT predict flight performance (except in the case of helicopters or 3D aircraft).

**Dynamic thrust measurements (measurements obtained when the propeller moves through the air) can be used to compute propeller efficiency, but are well beyond the average modeler.**

**It is easier (and far cheaper) to use E-power flight emulation programs (such as E-Calc and MotoCalc) to “what if” prop choices to optimize flight performance.**

# **Propeller Forces myths debunked!**

---

A rotating propeller and the air that passes through it, exert forces (in addition to thrust) on a vehicle. They are grouped and sub-grouped accordingly.

**Direct effects (not configuration dependant):**  
torque, P-effect, gyroscopic

**Indirect effects (configuration dependant):**  
swirl (spiraling slipstream), flow separation, flow reattachment

# Propeller Forces myths debunked!

---

The tendency of the airplane to **turn** (roll, yaw or both) to the left (with a clockwise turning prop when viewed from the cockpit) is made up of four elements which cause a rotation around at least one of the airplane's three axes. These four elements are:

1. Torque Reaction from Engine (motor) and Propeller.
2. Gyroscopic Action of the Propeller.
3. Asymmetric Loading of the Propeller (P Factor).
4. Corkscrewing Effect of the Slipstream (very configuration dependant).

Tom Hunt WRAM 2009

# Propeller Forces ..... Torque

Torque reaction involves Newton's Third Law of Physics—for every action, there is an equal and opposite reaction. As applied to the aircraft, this means that as the motor and propeller are revolving in one direction, an equal force is trying to rotate the airplane in the opposite direction.

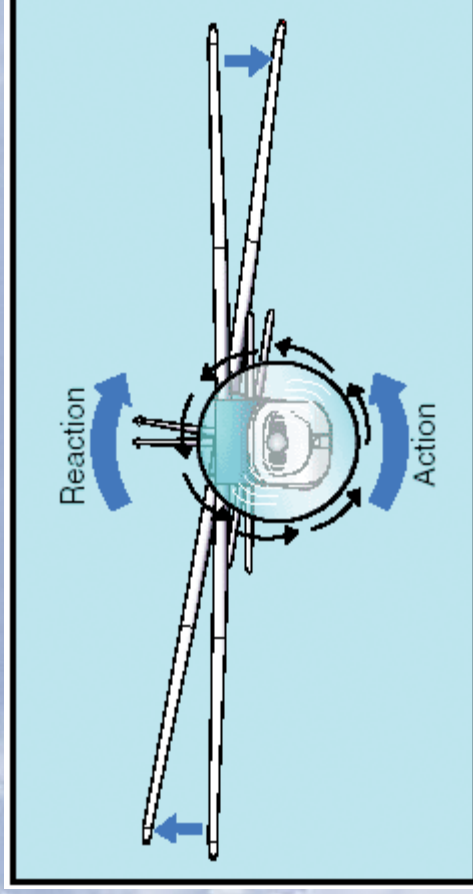

Tom Hunt WRAM 2009

# Propeller Forces ..... P-effect

When an airplane is flying with a high angle of attack, the “bite” of the downward moving blade is greater than the “bite” of the upward moving blade; thus moving the center of thrust to the right of the prop disc area—causing a yawing moment toward the left around the vertical axis.

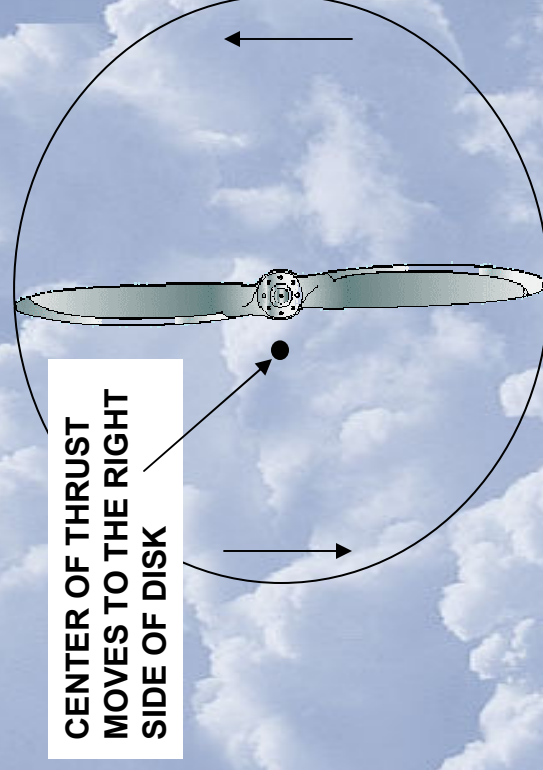
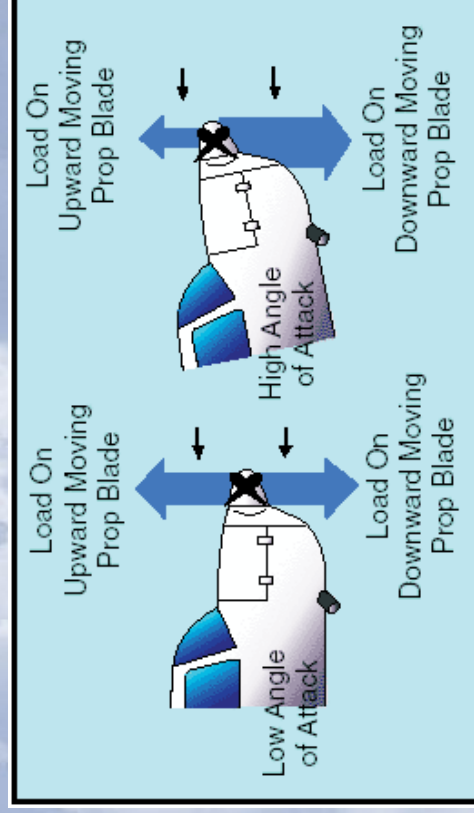

VIEW LOOKING AFT

Tom Hunt WRAM 2009

# Propeller Forces Gyroscopic Precession

Precession is the resultant action, or deflection, of a spinning rotor when a deflecting force is applied to its rim. When a force is applied to a rotating object, the resulting force takes effect  $90^\circ$  to the direction of rotation. When an aircraft tail is raised (such as a tail-dragger taking off)...the nose wants to go left.

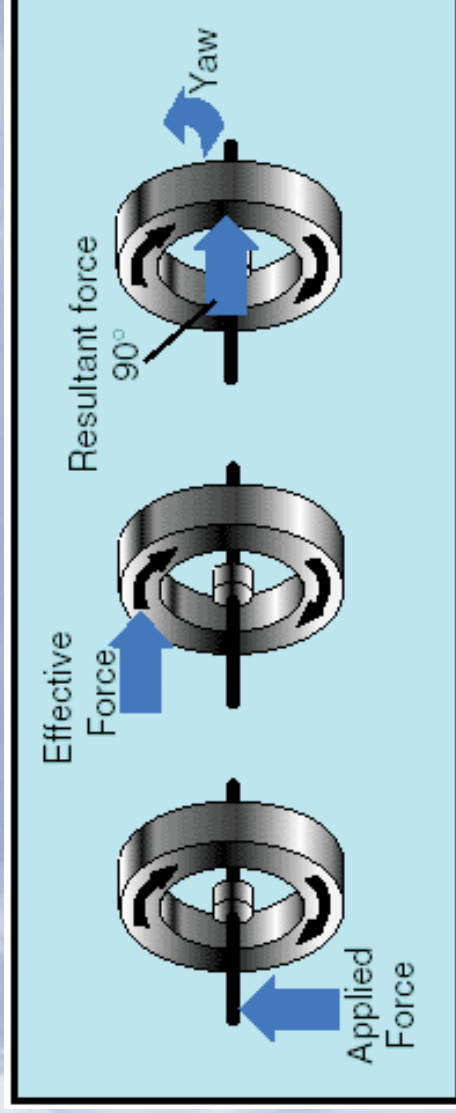



# Propeller Forces *slipstream effects*

The high-speed rotation of an airplane propeller gives a corkscrew or spiraling rotation to the slipstream. This “spiral” diminishes quickly with distance away from the prop plane and is weakened by the presence of a wing or tail ahead of the vertical tail.

This “indirect” effect is HIGHLY configuration dependant (overall shape of the aircraft and position of wings and tails) and even in the worst case can be the smallest of the indirect forces.

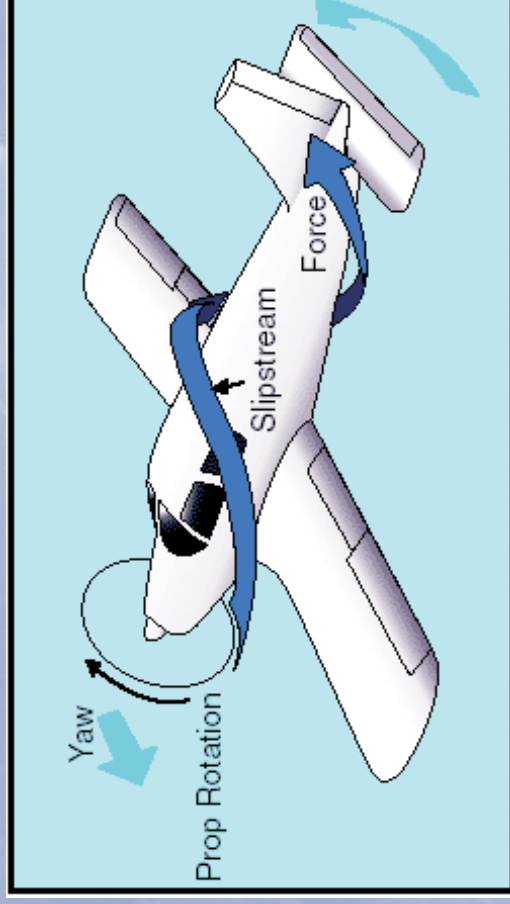

Tom Hunt WRAM 2009

# Choosing Propellers

**Ultimately, a wattmeter chooses propellers, not a organic sentient being! But we need somewhere to start.**

**Begin the process by asking oneself “How do I want to fly the model?”; or in the case of a scale model, “how was the full-scale aircraft flown?”**



# Choosing Propellers

---

## What field conditions do I have to deal with?

- **Trees? (need to climb steeply on takeoff)**
  - Gravitate towards low-medium P/D ratios
- **Thick lush grass? (need lost of thrust to overcome drag in the grass?)**
  - Gravitate towards low-medium P/D ratios
- **Poor runway surface ( lotsa lumps and bumps – need more ground clearance or spend lotsa money on more props!)**
  - Medium to high P/d ratios (favoring smaller diameter props)
- **Altitude? (flying at mile-high Denver?)**
  - Need more diameter AND pitch than at sea-level

# Choosing Propellers

---

## What physical limits do I have to deal with?

- Ground clearance
- Nacelle-fuselage clearance (multi-engine)
- Motor RPM limits
- Motor current limits (**remember the wattmeter?**)
- ESC current limits (**remember the wattmeter?**)

# Choosing Propellers

---

**Wood? Glow? Slow flyer? Electric?**

**A very wise aerospace engineer once told me:**

***Tom, the difference between a good prop and a bad prop is about 5%.***

**In other words... There is really no such thing as a “**bad prop**”, only the “**wrong prop**”. If you’re in the business to make props and “understand” them fairly well, a modeler is not going to see much difference in performance between manufacturers.**

**You can do more harm in making a poor choice of “size” than you ever can by choosing a manufacturer!**

Tom Hunt WRAM 2009

# Choosing Propellers

---

## Wood? Glow?

**Wood props can and should be used on scale models that had wood props on them. They look better and will not suffer greatly in lost performance over a “true” electric prop. The other nice thing about wood props is that they can be reshaped by the modeler to be more “scale-looking)**

**Glass filled “glow props” can be used anytime there is not a weight concern (they are generally heavier than “E-Props”) and the RPM they are spinning are closer to that you would find on a “glow engine”. Glow props are usually “thick” in the hub to withstand the beating of the power stroke in reciprocating engine. This generally makes them a bit more “draggy” than E-series props, but often these thicker regions are covered over with a spinner.**

Tom Hunt WRAM 2009

# Choosing Propellers

---

## Slow flyer? Electric?

**Slow flyer props are for just that..... models that fly slow. They generally have a higher “activity factor” (to absorb more power at lower RPMs) and are thin in cross section (to reduce weight). Slow flyer props, when “over sped”, absorb more power than they convert to useful thrust. They are generally too flexible to be “efficient” at higher power levels. I never met a “slow flyer” prop I liked above 120watts. Use E-series props above this level.**

**E-series propellers offer the best of performance of any other type of prop available above 120 watts of input. Their relatively thin cross section and low airfoil camber reduces drag, putting less burden on our motors, batteries and ESC’s.**

Tom Hunt WRAM 2009

# Multi-blade Propellers

---

**Why would I want to use one?**

**You made a poor choice of motor/battery combination for a particular model.**

**We learned earlier that one of the ways to extract the Hp we need from our electric motor to fly our model is to add diameter, increase the blade area or add more blades.**

**Adding diameter may be impractical due to ground clearance requirements.**

**Finding a different manufacturer that makes the same prop (pitch and diameter) with more blade area per blade is probably wasted effort.**

**Buying a 3 (or even 4) blade prop may be the only solution to “repair” the poor original choice of motor/battery.**



# Multi-blade Propellers

---

**Why would I want to use one?**

**You would like your scale model to “look” more scale on the ground and in the air.**

**If... and this is a big “IF” ..... you chose a motor that was capable of swinging a BIG scale like multi-bladed prop, the performance of the model can still be “exceptional” as well as very scale-like with just some loss in top speed (over a 2 bladed prop).**

**One must enter the process of knowing that a multi-bladed prop is in the running BEFORE making a decision on a motor.**

Tom Hunt WRAM 2009

# Multi-blade Propellers

Multi-bladed props, of “proper” design are generally not a proportional increase in total blade area, i.e. a 3 blade prop of the same diameter of a 2 blade props does NOT have exactly 1.5 X more blade area.



**MASTER AIRSCREW  
10X5 GF SERIES  
SINGLE BLADE AREA = 2.77 SQIN \***



**MASTER AIRSCREW  
10X5 GF 3 BLADE SERIES  
SINGLE BLADE AREA = 2.46 SQIN \***

\* Note: area of “exposed” blade area outside a typical spinner.

# Multi-blade Propellers

**Since we know that pitch has very little influence on the power absorbed of a prop, one can estimate the “equivalent” prop based on diameter.**

**From Martin Hepperle’s website:**

<http://www.mh-aerotoools.de/airfoils/index.htm>

Going from a 2 bladed prop to a 3 bladed prop, reduce the diameter by 10%, keeping the pitch the same.

Going from a 2 bladed prop to a 4 bladed prop, reduce the diameter by 16% keeping the pitch the same.

Experimentally, I have found that if I change from an APC “e-series” prop to a Master Airscrew 3 bladed prop, not only do I use this relationship, but I find that I should increase the pitch an inch or so (regardless of the diameter). This is mainly due to the fact that the blade area increase from 2 to 3 is not proportional and the new 3 bladed prop does not quite absorb the power computer (or needed)

Tom Hunt WRAM 2009

# Multi-blade Propellers

---

**What happens if you do not change the diameter between 2 blade and a 3 or 4 bladed prop?**

**Power consumption increases approximately 15-20% going between a 2 bladed prop and a 3 bladed prop with only a 10-12% increase in thrust, however, the speed of the model will drop by 5-8%!**

**Power consumption increases approximately 30% going between a 2 bladed prop and a 4 bladed prop with only a 20% increase in thrust, however, the speed of the model will drop by 12-15%!**

# Multi-blade Propellers



Just plain silly! Prop is WAY too small. Would get better performance with the “proper” 2 blade prop!

Scale “deHavilland “needle” props



Very cool and flies well too!



Looks about right! Too bad the gear are too short and wheels too small!



Yes Martha, you can see it in the air!

Tom Hunt WRAM 2009

# Choosing propellers

## A tale of two "40 glow" Spitfires

PLANE	SPITFIRE - SMALL PROP	SPITFIRE -LARGE PROP
MOTOR	AXI 2820/12	AXI 4130/16
PROP	10 X 6 (2 BLADE)	15 X 10 (3 BLADE)
PROP RPM	12,790	5750
WATTS	745	598
MOTOR AMPS	44.7	34.9
SYSTEM EFF	70	77
MOTOR EFF	79	84
P/D	0.6	0.666
WATTS/LB	149	115
CLIMB FT/MIN	2569	2600
MAX MPH	79	68

SLIGHTLY BIGGER/HEAVIER MOTOR MIGHT MAKE MODEL EASIER TO BALANCE

BIG-VERY COOLING LOOKING AND SCALE LIKE PROP!

SUBSTANTIALLY LOWER CURRENT! COOLER RUNNING MOTOR AND BATTERIES! LONGER LIFE!

BETTER MOTOR AND SYSTEM EFFICIENCY!

SIMILAR CLIMB RATES!

SMALLER PROP FASTER.... BUT DO YOU REALLY NEED TO GO 80 MPH?

Tom Hunt WRAM 2009



# **THE END**

## **Questions?**

### **MIND THAT PROPI!**

### **FLY CLEAN!**

### **FLY QUIET!**

### **FLY AND CHARGE SAFELY!**

Tom Hunt WRAM 2009